



LEOPARD

14 | 18 | 21 | 25



≥ SALI CON NOI ↗ CLIMB WITH US ↗ MONTE AVEC NOUS ↗ STEIGEN SIE MIT UNS AUF ↗ SUBE CON NOSOTROS ↗ ПОДНИМАЙТЕСЬ С НАМИ

100% HYDRAULIC

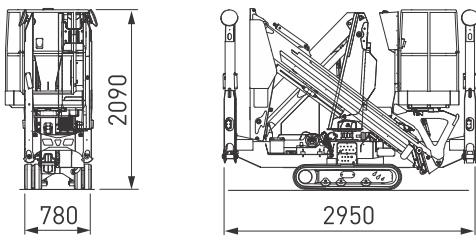

14 m	6,5 m	200 kg	400°	90°+ 90°	

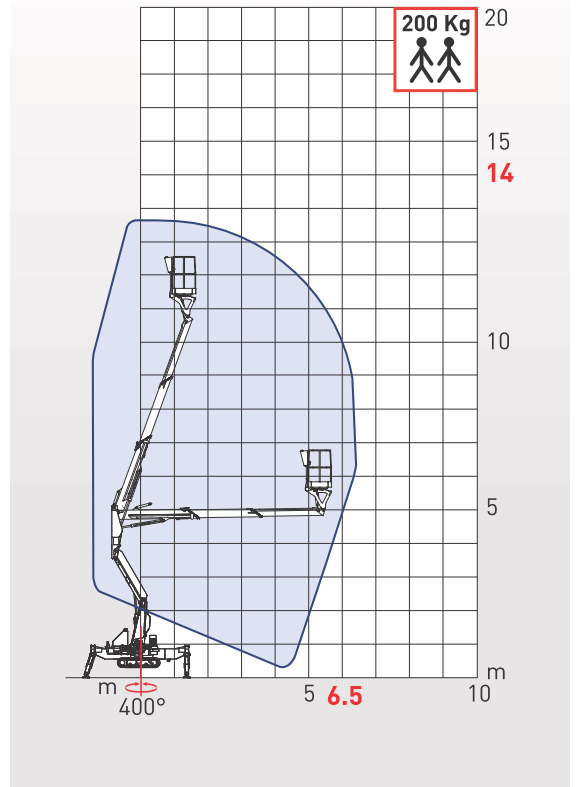

ELECTRO-HYDRAULIC

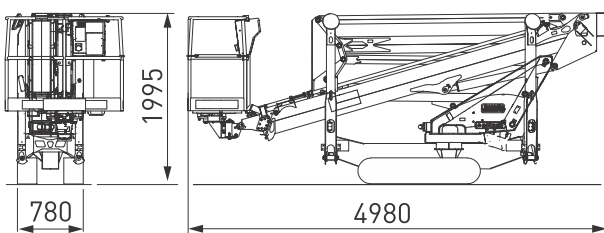

17 m	7,5 m	250 kg	400°	90°+ 90°	

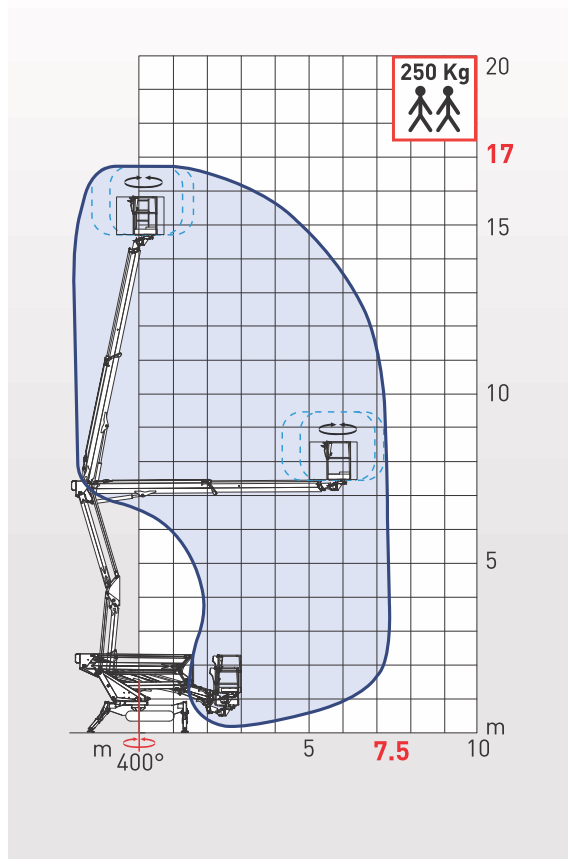

ELECTRO-HYDRAULIC

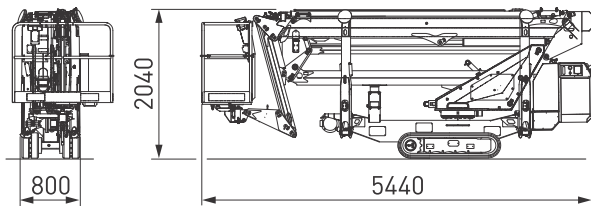
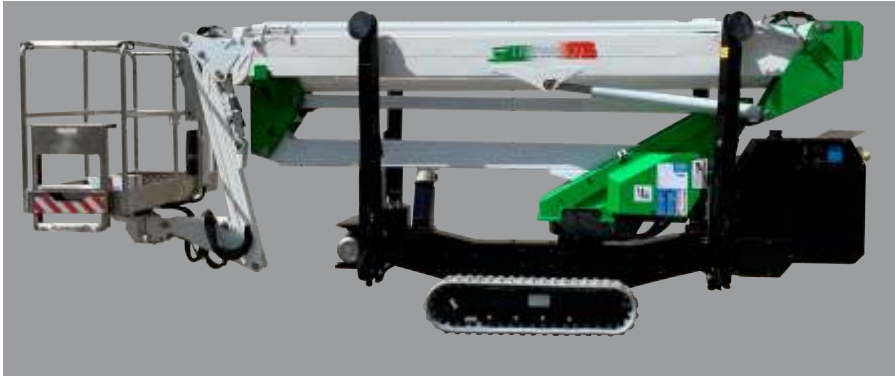

21 m	9 m	250 kg	400°	90°+90°	

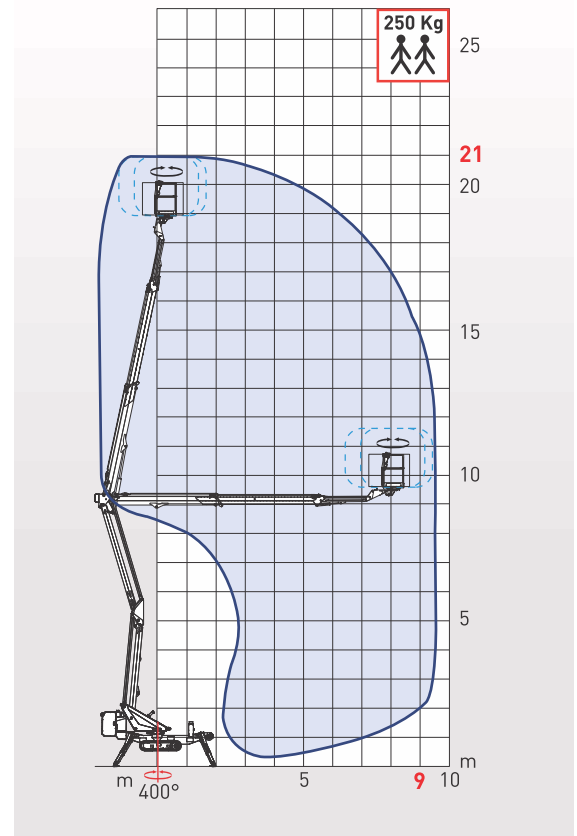

ELECTRO-HYDRAULIC

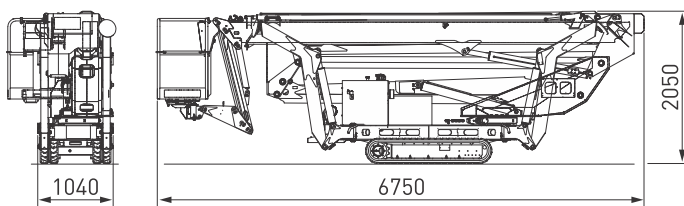

25 m	11,5 m	250 kg	400°	90°+90°	

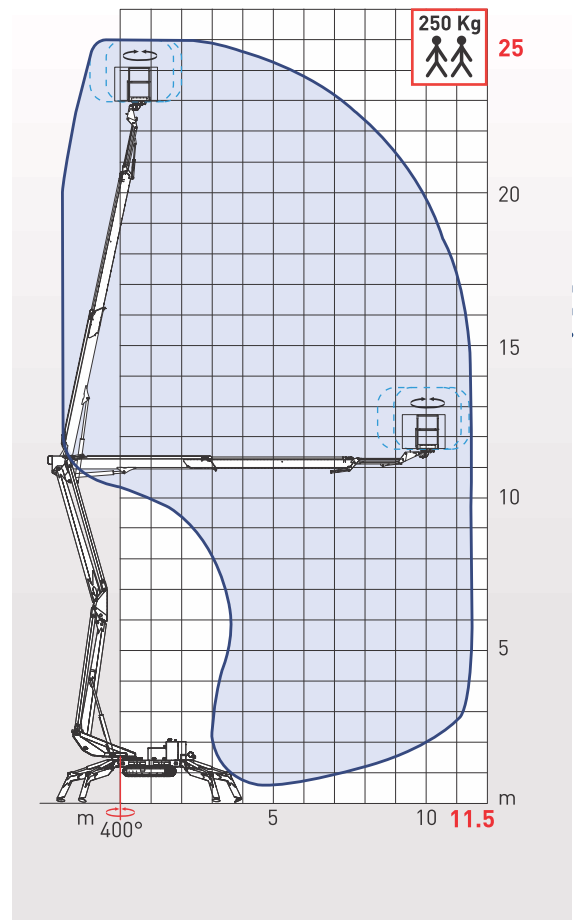

LEOPARD

14 18 21 25

Tecnologia e sicurezza per lavorare in quota
Safety and technology for aerial works
Technologie et sécurité pour travaux aériens
Technologie und Sicherheit bei der Arbeit in der Höhe
Tecnología y seguridad por trabajos aéreos
Технология и безопасность для работы на высоте



- Altezza di lavoro da 14 a 25 m
- Sbraccio laterale fino a 11.5 m
- Max portata in navicella 250 kg
- Rotazione torretta: 400° per il modello 14m, 400° per i modelli 18, 21, 25 m
- Sottocarro cingolato allargabile (modelli 18, 21 e 25 m)
- Doppia velocità
- Versione con batteria al litio disponibile
- Comandi elettro-idraulici proporzionali
- Radiocomando wireless per tutte le funzioni
- Motore a benzina
- Presa elettrica 230 V in navicella
- Motore elettrico supplementare 230 V
- Cingolo anti-traccia



- Working height from 14 to 25 m
- Lateral outreach up to 11.5 m
- Basket capacity max. of 250 kg
- Turret rotation: 400° for 14 m model, 400° for 18, 21 and 25 m models
- Extendable crawler undercarriage (18, 21 and 25 m models)
- Dual speed
- Lithium battery version
- Proportional electro-hydraulic controls
- Wireless remote control
- Petrol engine
- Electric power socket 230 V in basket
- Supplementary electric engine 230 V
- Non-marking crawler track



- Hauteur de travail de 14 à 25 m
- D port latéral jusqu'à 11.5 m
- Capacité du panier max. 250 kg
- Rotation de la tourelle: 400° pour le modèle 14 m, 400° pour les modèles 18, 21, 25 m
- Train de chenilles extensible (modèles 18, 21 et 25 m)
- Double vitesse
- Version avec batterie au lithium disponible
- Commandes électro-hydrauliques proportionnelles
- Télécommande sans fil pour toutes les fonctions
- Moteur essence
- Prise électrique 230 V dans la nacelle
- Moteur électrique supplémentaire de 230 V
- Protecteur de voie



- Arbeitshöhe zum 14 bis 25 m
- Seitliche Reichweite bis 11.5 m
- Tragkraft im Korb max. 250 kg
- Drehung des Turms: 400° für das Modell 14 m, 400° für die Modelle 18, 21 und 25 m
- Ausziehbarer Raupenunterwagen (Modelle 18, 21 und 25 m)
- Doppelte Geschwindigkeit
- Version mit Lithium-Batterie
- Proportionale elektro-hydraulische Steuerung
- Kabellose Fernsteuerung
- Benzinmotor
- Steckdose 230 V im Korb
- Zusätzlicher Elektromotor 230 V
- Nicht markierendes Raupenfahrwerk



- Altura de trabajo a partir el 14 de 25 m
- Alcance lateral hasta 11.5 m
- Capacidad máxima en la cesta de 250 kg
- Rotación de la torreta: 400° para el modelo 14m, 400° para los modelos 18, 21, 25 m
- Tren de rodaje extensible sobre orugas (modelos 18, 21 y 25 m)
- Doble velocidad
- Versión de batería de litio disponible
- Controles electrohidráulicos proporcionales
- Mando a distancia inalámbrico para todas las funciones
- Motor de gasolina
- Toma de corriente de 230 V en la cesta
- Motor eléctrico adicional de 230 V
- Guarda de pista



- Рабочая высота от 14 до 25 метров
- Вылет до 11.5 метров
- Грузоподъемность люльки 250 Кг.
- Вращение колонны 400° во модели Leopard 14, 400° в моделях Leopard 18, 21 и 25
- Раздвижной гусеничный шасси
- Два скоростных режима
- Возможная комплектация с литиевым аккумулятором
- Пропорциональный электро-гидравлический контроль
- Беспроводной пульт управления
- Бензиновый двигатель
- Розетка с электроприводом 230 Вольт в корзине
- Дополнительный электрический двигатель
- Белые гусеницы

CO.ME.T.Bharat reserves itself the right to make changes to project without notice.



COMET BHARAT

530, C - Block, Floor - P5, NPX Tower, Sector -153, Noida - 201310 |U.P.| India
Email: sales@cometbharat.com | Call: +91 72178 86471